

Switching Boost Regulator



General Description

The FP6201 is a boost topology switching regulator for wide operating voltage applications. The FP6201 includes a high current N-MOSFET, a high precision reference (0.5V) for comparing output voltage with feedback amplifier, an internal dead-time control and oscillator for controlling the maximum duty cycle and PWM frequency. It also has power on programmable soft start time, short circuit NMOS turn-off and auto re-start protection functions.

Features

- Wide Supply Voltage Operating Range: 3.6 to 20V
- Built-in N-MOSFET for 2A Loading Capability
- Precision Feedback Reference Voltage: 0.5V (2%)
- Internal Fixed Oscillator Frequency: 320KHz (Typ.)
- Low Current Consumption: 3mA
- Programmable Soft-Start Function (SS)
- Short Circuit Shutdown and Auto Re-start Function(ARSCP)
- Output Adjustable to 20V
- Over Current Protection
- Package: SOP-8L

Typical Application

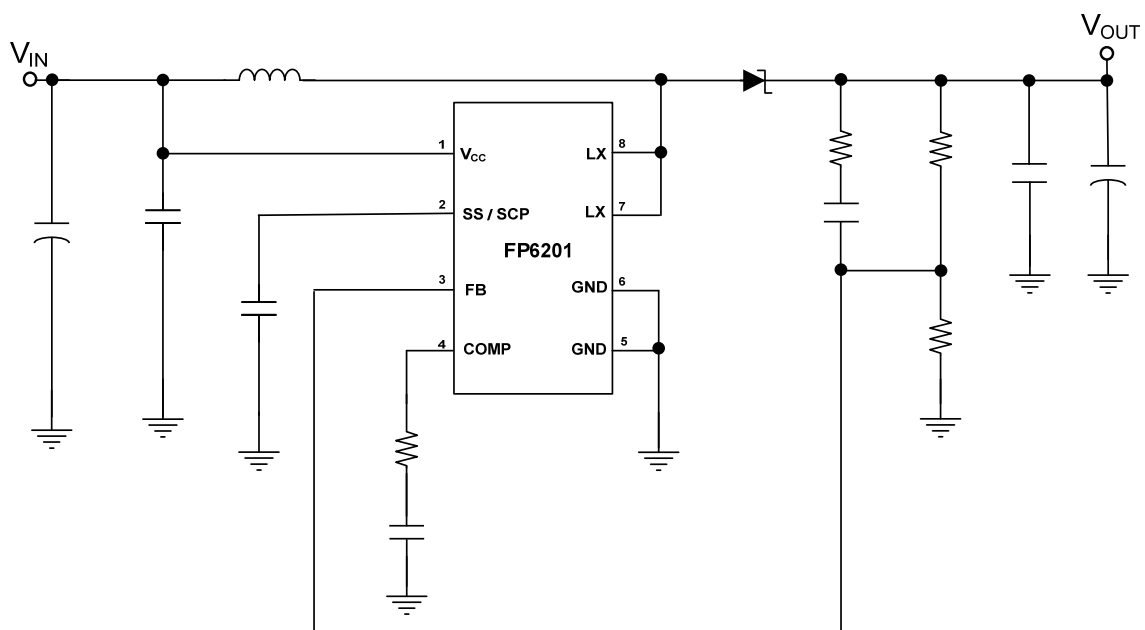

Last saved by Hsieh_hp This datasheet contains new product information. Feeling Technology reserves the rights to modify the product specification without notice.

No liability is assumed as a result of the use of this product. No rights under any patent accompany the sales of the product.

Function Block Diagram

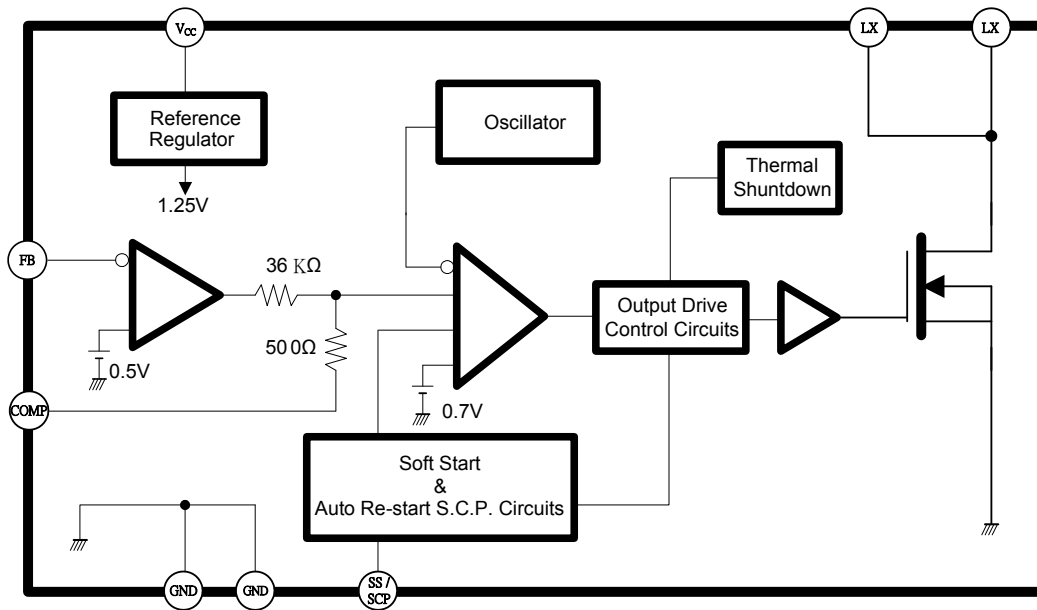

Pin Descriptions

SOP-8L

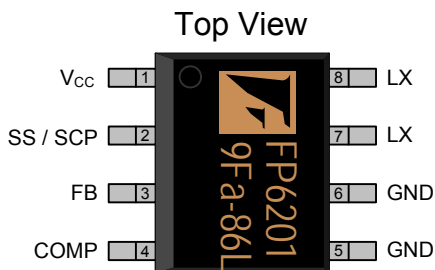

Name	No.	I / O	Description
V _{CC}	1	P	IC Power Supply
SS / SCP	2	I	Connecting with a Soft-start & ARSCP Timing Capacitor
FB	3	I	Error Amplifier Inverting Input
COMP	4	O	Error Amplifier Compensation Output
GND	5	P	IC Ground
GND	6	P	IC Ground
LX	7	O	Switch Output
LX	8	O	Switch Output

Marking Information

SOP-8L

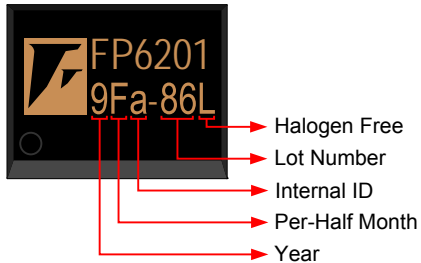

Halogen Free: Halogen free product indicator

Lot Number: Wafer lot number's last two digits

For Example: 132386TB → 86

Internal ID: Internal Identification Code

Per-Half Month: Production period indicated in half month time unit

For Example: January → A (Front Half Month), B (Last Half Month)

February → C (Front Half Month), D (Last Half Month)

Year: Production year's last digit

Ordering Information

Part Number	Operating Temperature	Package	MOQ	Description
FP6201DR-LF	-40°C ~ +85°C	SOP-8L	2500EA	Tape & Reel

Absolute Maximum Ratings

Parameter	Symbol	Conditions	Min.	Typ.	Max.	Unit
Power Supply Voltage	V _{CC}				+20	V
NMOS Drain Sink Current					+3	A
LX to GND	V _{LX}				20	V
Error Amplifier Inverting Input	V _{FB}		-0.3		1.2	V
Allowable Dissipation (SOP-8L)		T _A ≤ +25°C			650	mW
Thermal Resistance Junction to Ambient	θ _{JA}				+175	°C / W
Thermal Resistance Junction to Case	θ _{JC}				+55	°C / W
Storage Temperature	T _s		-55		+125	°C
ESD Susceptibility		HBM (Human Body Mode)		2		KV
		MM (Machine Mode)		200		V
Lead Temperature (soldering, 10 sec)					+260	°C

IR Re-flow Soldering Curve

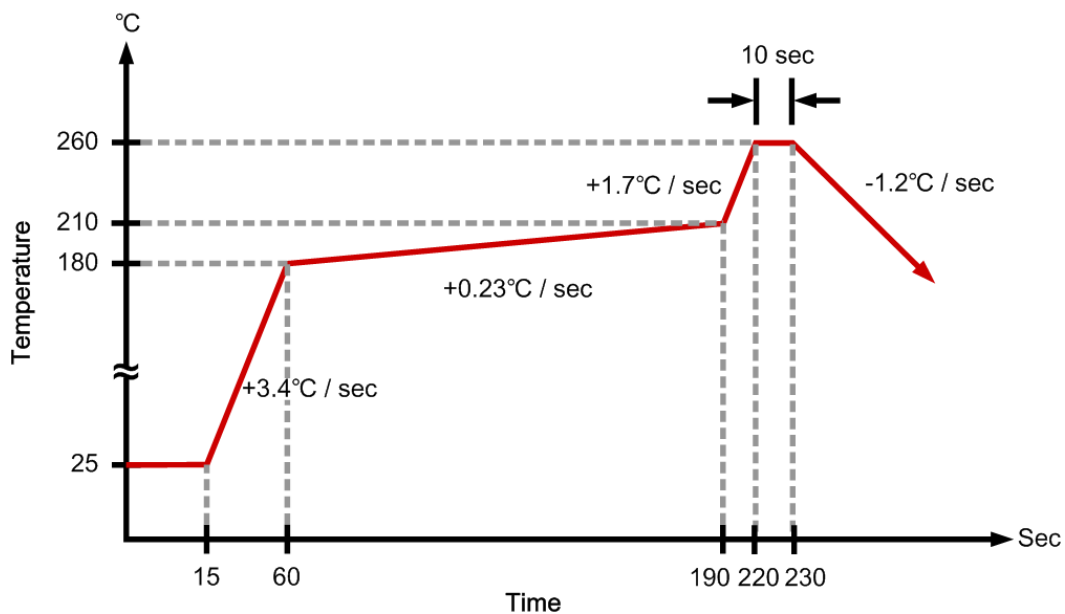

Last saved by Hsieh_hp This datasheet contains new product information. Feeling Technology reserves the rights to modify the product specification without notice.

No liability is assumed as a result of the use of this product. No rights under any patent accompany the sales of the product.

Recommended Operating Conditions

Parameter	Symbol	Conditions	Min.	Typ.	Max.	Unit
Supply Voltage	V_{CC}		3.6		+20	V
Operating Temperature			-10		+85	°C

DC Electrical Characteristics ($V_{IN}=20V$, $T_A=25^\circ C$, unless otherwise noted)

Parameter	Symbol	Test Conditions	Min.	Typ.	Max.	Unit
Reference						
Output Voltage	V_{REF}	COMP connected to FB	0.490	0.5	0.510	V
Input Regulation	ΔV_{REF}	$V_{CC} = 3.0V$ to $20V$		2	12.5	mV
Output Voltage Change with Temperature	$\Delta V_{REF} / V_{REF}$	$T_A = -10^\circ C$ to $25^\circ C$		1	2	%
		$T_A = 25^\circ C$ to $85^\circ C$		1	2	
Soft Start Section (S.S.)						
S.S. Source Current	I_{SS}	$V_{SS} = 0V$	-15	-10	-7	μA
Soft Start Threshold Voltage	V_{SST}		0.8	0.9	1.0	V
Short Circuit Protection Section (S.C.P.)						
S.C.P. Source Current	I_{SCP}	$V_{SCP} = 0V$	-15	-10	-7	μA
SCP re-start / Hold Time	T_{RS} / T_{HOLD}	$V_{COMP} > 0.8V$		1 / 10		
S.C.P. Threshold Voltage	V_{SCP}	$V_{comp} > 450mV$	0.9	1.0	1.1	V
	V_{SB}	$V_{comp} < 450mV$		0.1	0.15	
Oscillator Section						
Oscillation Frequency	f			320		KHz
Frequency Change with Voltage	$\Delta f / \Delta V$	$V_{CC} = 4V$ to $15V$		5		%
Frequency Change with Temperature	$\Delta f / \Delta T$	$T_A = -10^\circ C$ to $+85^\circ C$		5		%
Thermal Shutdown Section						
Thermal Shutdown Temperature				+145		°C
Error Amplifier Section						
Input Bias Current	I_B		-1.0	-0.2	1.0	μA
Voltage Gain	A_v			100		V / V
Frequency Bandwidth	BW	$A_v = 0$ dB		6		MHz
Output Voltage Swing (Positive)	V_{POS}	$V_{FB} = 0.3V$	0.78	0.87		V
Output Voltage Swing (Negative)	V_{NEG}	$V_{FB} = 0.7V$		0.05	0.2	V
Output Source Current	I_{SOURCE}	$V_{comp} = 500mV$	-30	-45		μA
Output Sink Current	I_{SINK}	$V_{comp} = 500mV$	30	45		μA
Idle Period Adjustment Section						
Maximum Duty Cycle	T_{DUTY}	$V_{FB} = 0.2V$		88		%
Total Device Section						
Average Supply Current	I_{AVE}			3.8	7	mA

Last saved by Hsieh_hp This datasheet contains new product information. Feeling Technology reserves the rights to modify the product specification without notice.

No liability is assumed as a result of the use of this product. No rights under any patent accompany the sales of the product.

Parameter	Symbol	Test Conditions	Min.	Typ.	Max.	Unit
Output Section						
NMOS D-S Voltage	V_{DSS}			60		V
NMOS Source Current	I_D			-2		A
NMOS on Resistance	$R_{DS(ON)}$	$V_{CC}=4.5V, V_{FB}=0V$		49	64	m Ω
		$V_{CC}=10V, V_{FB}=0V$		33	41	
Output Leakage Current	I_L	SCP Active		5		μ A
Over Current Protection Section						
NMOS OCP Current	I_{OCP}			3		A

Typical Operating Characteristics ($V_{IN}=7V, T_A=25^{\circ}C$, unless otherwise noted)

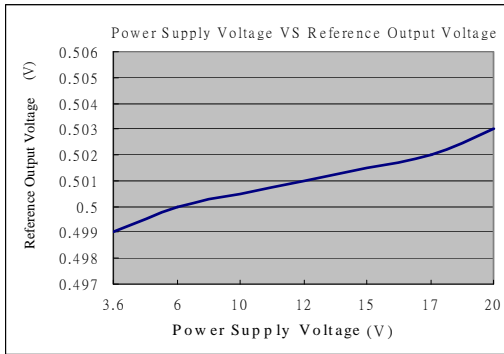

Figure 1

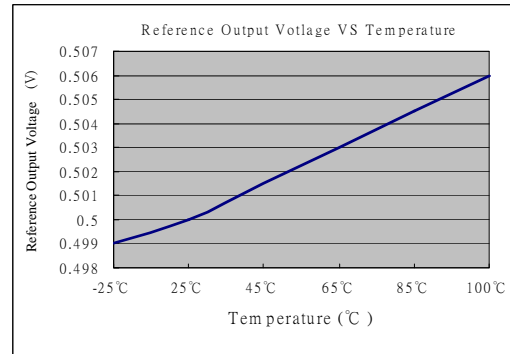

Figure 2

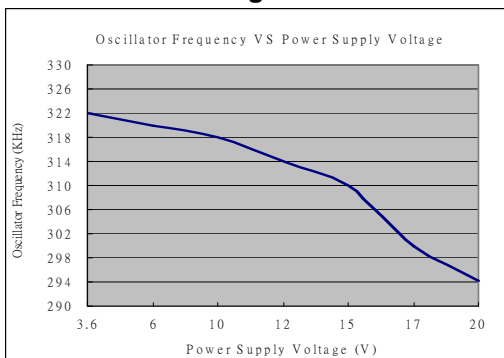

Figure 3

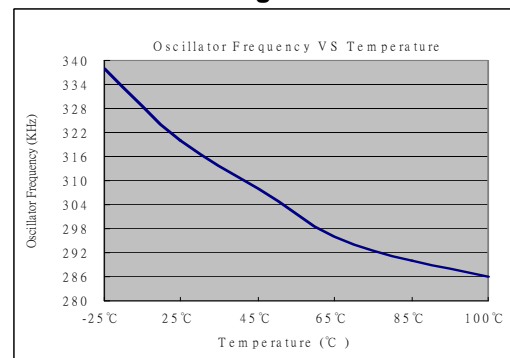

Figure 4

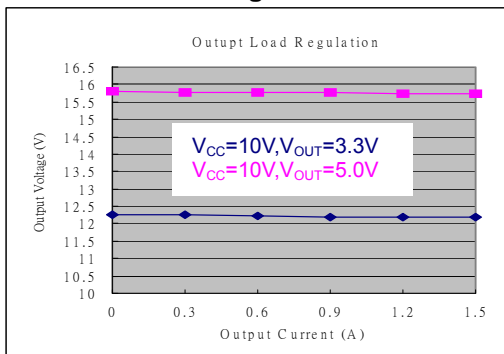

Figure 5

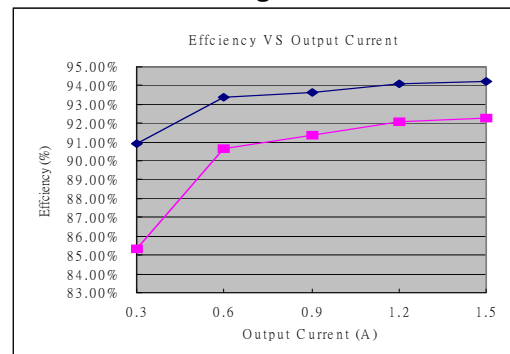

Figure 6

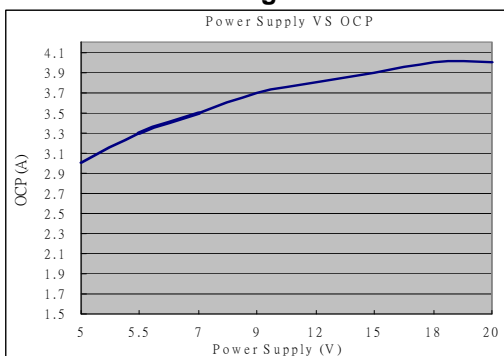

Figure 7

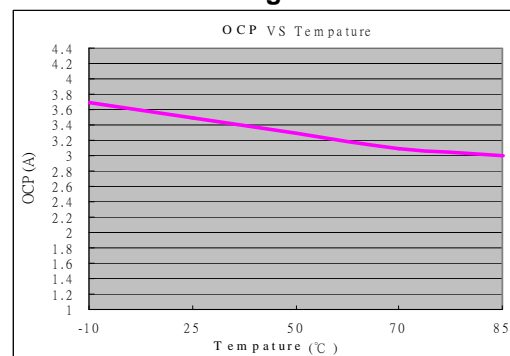
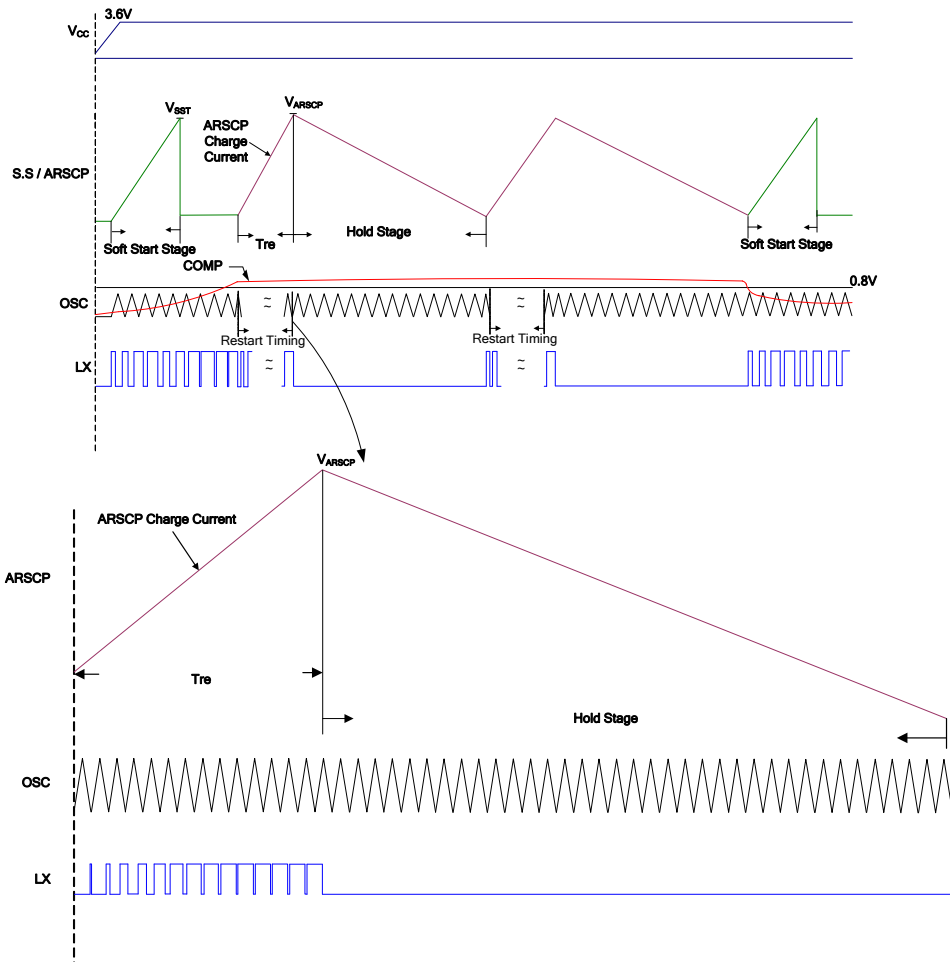

Figure 8

Last saved by Hsieh_hp This datasheet contains new product information. Feeling Technology reserves the rights to modify the product specification without notice.

No liability is assumed as a result of the use of this product. No rights under any patent accompany the sales of the product.

Timing Waveform



Last saved by Hsieh_hp This datasheet contains new product information. Feeling Technology reserves the rights to modify the product specification without notice.

No liability is assumed as a result of the use of this product. No rights under any patent accompany the sales of the product.

Application Information

Voltage Reference

The FP6201 includes a 1.25V reference voltage generator. This voltage is connected to a resistive divider to generate a 0.5V precision reference voltage to the non-inverting input of error amplifier and 1.0V to the SCP comparator.

Error Amplifier

The error amplifier compares a sample of the DC-DC converter's output voltage with the 0.5V (V_{REF}) reference and generates an error signal for the PWM comparator. Output voltage of DC-DC converter is setting by the resistor divider with the following equation (figure 9):

$$V_{OUT} = \left(1 + \frac{R1}{R2}\right) \times V_{REF}$$

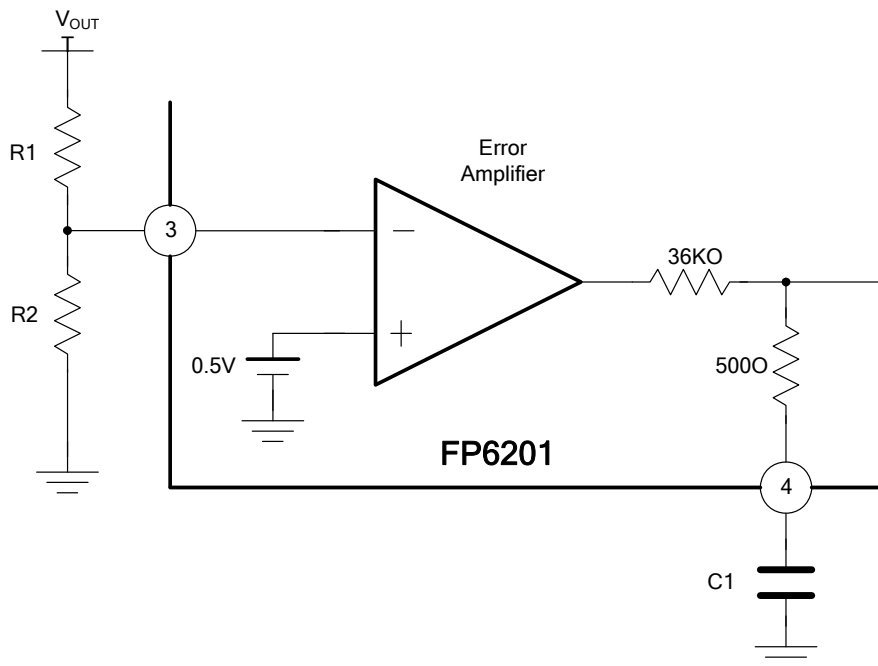

Figure 9 Error Amplifier with Feedback Resistance Divider

Oscillator

The fixed PWM frequency is generated by an internal RC oscillator. Its typical value is 320KHz.

Soft Start / Short-Circuit Protection (S.S. / S.C.P.)

The soft start is enabled after power on. The interval of soft start time is determined by a capacitor connected to SCP pin. After the soft start finished, the internal soft start clamp voltage is setting high, but the external SCP pin is discharged to low. Thus FP6201 turns on short circuit detection / protection function.

The time of soft start is:

$$T_{ss}(ms) = 0.07 \times C(\mu F)$$

When a heavy loading or short circuit condition make output voltage to drop too much, the error amplifier output will rise to very high. Once COMP pin voltage exceeds V_{POS} (typ. 1.0V), the short circuit protection function is triggered. The output switching MOS will be turned off. The SCP capacitor will be charged until it potential exceeds SCP threshold voltage (typ. 1.2V) and then discharged to ground.

The time of short circuit protection is:

$$T_{SCP} = \frac{V \times C_{SCP}}{I} = \frac{(V_{TH} - V_{SS-start}) \times C_{SCP}}{I_{source}} = 0.09 \times C_{SCP}(\mu F)$$

Restart timing of short circuit protection is:

$$T_{scp} = 1.8 \times C[\mu F]$$

Thermal Protection

When a heavy loading makes chip internal temperature exceeds 145°C, the thermal protection function is triggered. The FP6201 turns off its output and starts Short Circuit Protection function. After the IC internal temperature is cooled down to below 145°C, it will turn on the output and execute Soft-Start function again.

Over Current Protection

When FP6201 senses driver current larger than 3A, it will initiate OCP function and enters ARSCP function. After current drops below 3A, FP6201 turns on the output and continues PWM operation.

Typical Application

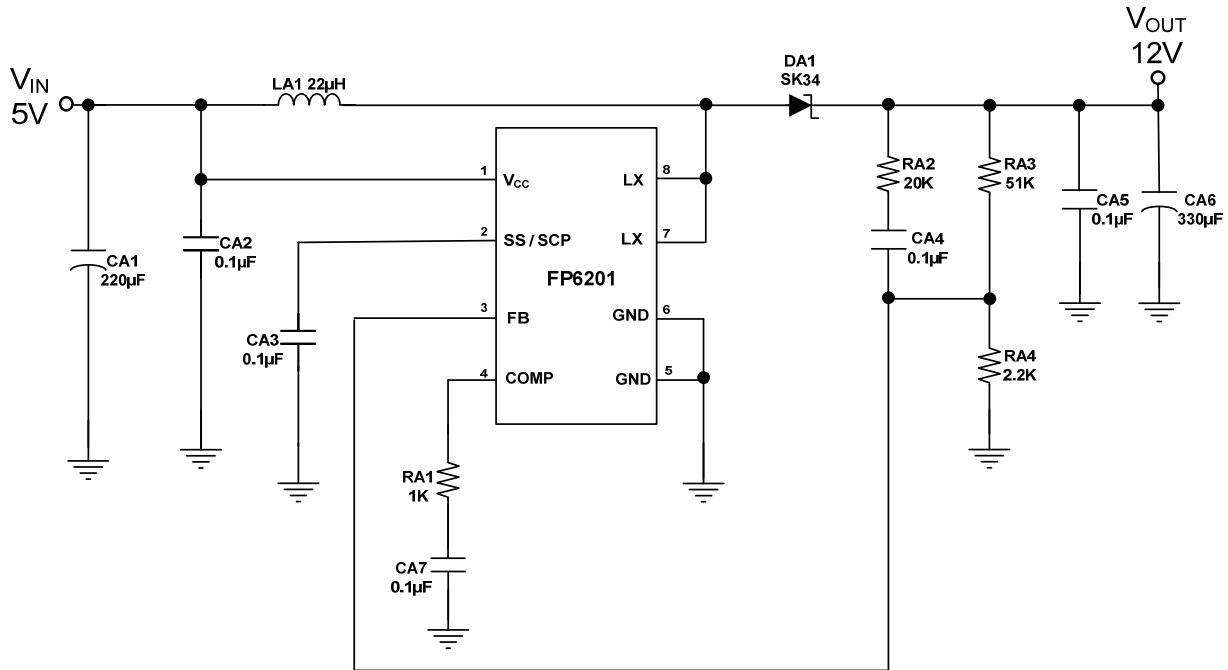

FP6201 Basic DC-DC Regulator Circuit

For example:

The V_{IN} power supply is 5.0V and the V_{OUT} is designed for 12V / 0.5A solution.

The output voltage equation is:

$$V_{OUT} = \left(1 + \frac{R_1}{R_2}\right) \times V_{IN} = \left(1 + \frac{56K\Omega}{2.43K\Omega}\right) \times 0.5V = 12.02V$$

Package Outline

SOP-8L

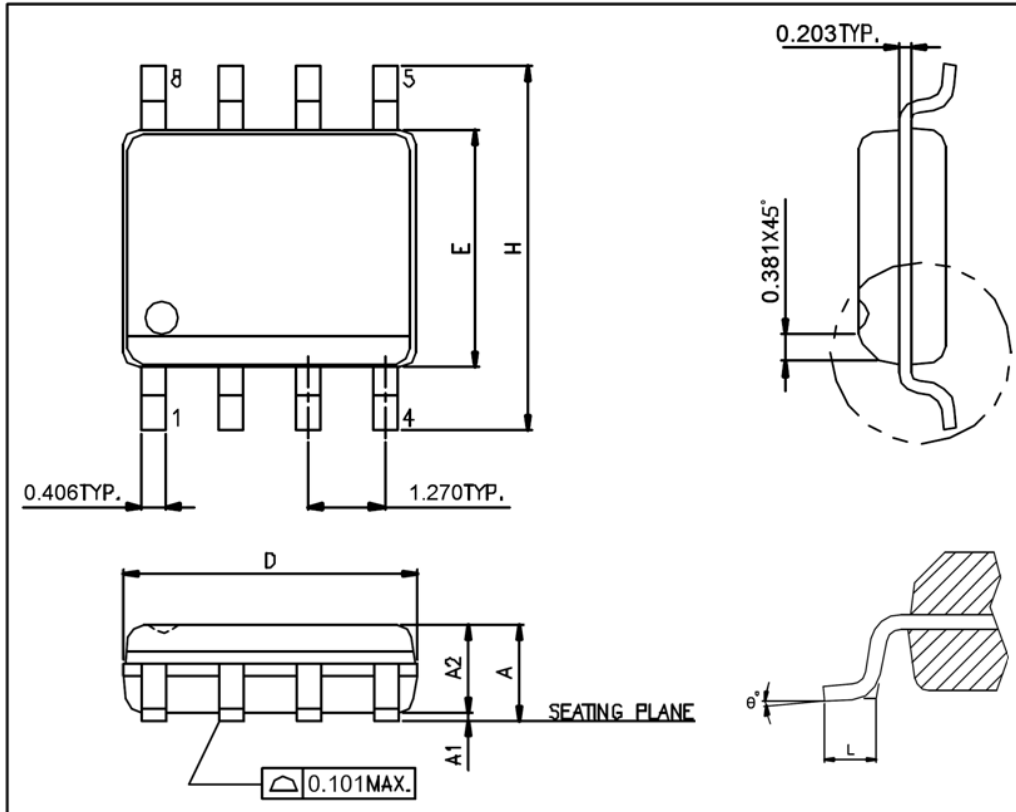

UNIT: mm

Symbols	Min. (mm)	Max. (mm)
A	1.346	1.752
A1	0.101	0.254
A2		1.498
D	4.800	4.978
E	3.810	3.987
H	5.791	6.197
L	0.406	1.270
θ°	0°	8°

Note:

1. Package dimensions are in compliance with JEDEC outline: MS-012 AA.
2. Dimension "D" does not include molding flash, protrusions or gate burrs.
3. Dimension "E" does not include inter-lead flash or protrusions.